

**BUSSOLA MASCHIO ESAGONALE  
IN DUE PARTI:  
BUSSOLA + INSERTO MASCHIO XZN**

<i>Koken</i> articolo		L mm	
14134X-58-M5	M 5	58	1
14134X-58-M6	M 6	58	1
14134X-58-M8	M 8	58	1
14134X-58-M10	M10	58	1
14134X-58-M12	M12	58	1
14134X-58-M14	M14	58	1
14134X-98-M5	M 5	98	1
14134X-98-M6	M 6	98	1
14134X-98-M8	M 8	98	1
14134X-98-M10	M10	98	1
14134X-98-M12	M12	98	1
14134X-98-M14	M14	98	1



**PROLUNGHE PER  
BUSSOLE  
"POWER IMPACT"  
MASCHIO/FEMMINA**

<i>FERMEC</i> articolo		L mm	
97-6	PERNO	50	1
97-6-75	PERNO	75	1
97-7	PERNO	125	1
97-8	PERNO	175	1
97-9	PERNO	250	1
97-6 S	SFERA	50	1
97-6-75 S	SFERA	75	1
97-7 S	SFERA	125	1
97-8 S	SFERA	175	1
97-9 S	SFERA	250	1
97-9-300 S	SFERA	300	1
97-9-460 S	SFERA	460	1
97-9-610 S	SFERA	610	1
97-9-915 S	SFERA	915	1

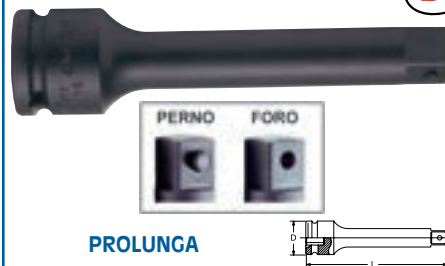

**PROLUNGA**

<i>Koken</i> articolo	D mm	L mm	
14760-50P	30 PERNO	50	1
14760-75P	30 PERNO	75	1
14760-100P	30 PERNO	100	1
14760-125P	30 PERNO	125	1
14760-150P	30 PERNO	150	1
14760-175P	30 PERNO	175	1
14760-200P	30 PERNO	200	1
14760-250P	30 PERNO	250	1
14760-50	30 FORO	50	1
14760-75	30 FORO	75	1
14760-100	30 FORO	100	1
14760-125	30 FORO	125	1
14760-150	30 FORO	150	1
14760-175	30 FORO	175	1
14760-200	30 FORO	200	1
14760-250	30 FORO	250	1

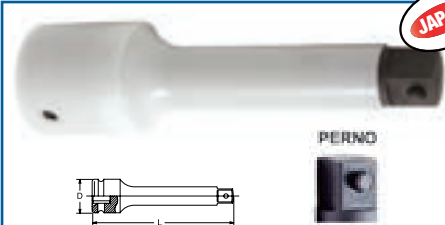

**CON RIVESTIMENTO ANTI-GRAFFIO  
PROLUNGA CON RIVESTIMENTO**

<i>Koken</i> articolo	D mm	L mm	
14760-75P.FR <small>NEW</small>	34.2	75	1
14760-125P.FR	34.2	125	1
14760-250P.FR	34.2	250	1



<i>BGS</i> articolo	DESCRIZIONE
BGS 190	<b>SNODO A MACCHINA</b>

**CARATTERISTICHE**

- finitura nera
- lunghezza: 70 mm
- con sfera di tenuta
- peso 170 g



<i>BGS</i> articolo	DESCRIZIONE
BGS 9459	<b>SET 3 PEZZI, SNODI</b>

**CARATTERISTICHE**

- con scanalatura e foro per spina
- comprende:
  - snodo 1/4" F - 1/4" M
  - snodo 3/8" F - 3/8" M
  - snodo 1/2" F - 1/2" M
- peso 420 g

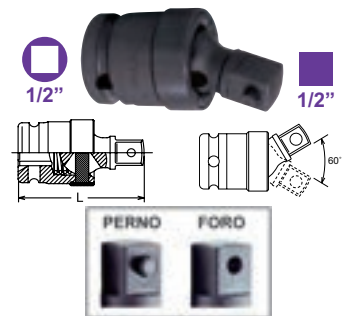

**SNODO UNIVERSALE**

<i>Koken</i> articolo		L mm	
14771-P	PERNO	65	1
14771	FORO	65	1

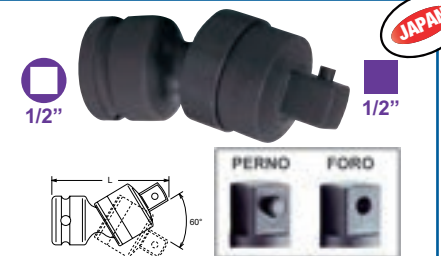

**SNODO UNIVERSALE**

<i>Koken</i> articolo		L mm	
14770-P	PERNO	74	1
14770	FORO	74	1