

JAPAN

XZN

**BUSSOLA MASCHIO ESAGONALE
IN DUE PARTI:
BUSSOLA + INSERTO MASCHIO XZN**

Koken articolo		L mm	
13134X-52-M5	M 5	52	1
13134X-52-M6	M 6	52	1
13134X-52-M8	M 8	52	1
13134X-52-M10	M10	52	1
13134X-52-M12	M12	52	1
13134X-52-M14	M14	52	1
13134X-92-M5	M 5	92	1
13134X-92-M6	M 6	92	1
13134X-92-M8	M 8	92	1
13134X-92-M10	M10	92	1
13134X-92-M12	M12	92	1
13134X-92-M14	M14	92	1

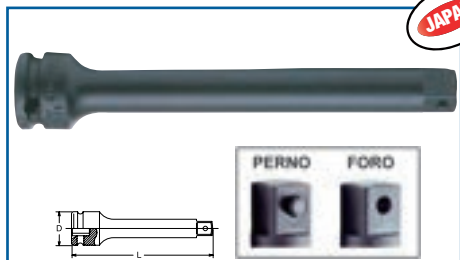

JAPAN

PROLUNGA

Koken articolo	D mm	L mm	
13760-50P	22	PERNO 50	1
13760-75P	22	PERNO 75	1
13760-100P	22	PERNO 100	1
13760-125P	22	PERNO 125	1
13760-150P	22	PERNO 150	1
13760-200P	22	PERNO 200	1
13760-250P	22	PERNO 250	1
13760-50	22	FORO 50	1
13760-75	22	FORO 75	1
13760-100	22	FORO 100	1
13760-125	22	FORO 125	1
13760-150	22	FORO 150	1
13760-200	22	FORO 200	1
13760-250	22	FORO 250	1



3/8"

3/8"

**PROLUNGHE PER BUSSOLA
"POWER IMPACT" MASCHIO/FEMMINA**

articolo		L mm	
97-3	PERNO	75	1
97-3-100	PERNO	100	1
97-3-125	PERNO	125	1
97-4	PERNO	150	1
97-4-200	PERNO	200	1
97-5-250	PERNO	250	1
97-5-300	PERNO	300	1
97-3-125 SWF	SGANCIO RAPIDO	125	1
97-3 S	SFERA	75	1
97-3-100 S	SFERA	100	1
97-3-125 S	SFERA	125	1
97-4 S	SFERA	150	1
97-4-200 S	SFERA	200	1
97-5-250 S	SFERA	250	1



JAPAN

**CON RIVESTIMENTO ANTI-GRAFFIO
PROLUNGA CON RIVESTIMENTO**

Koken articolo	D mm	L mm	
13760-75P.FR	26.2	75	1
13760-125P.FR	26.2	125	1
13760-250P.FR	26.2	250	1



3/8"

PRO+

CROMO

3/8"

BGS articolo	DESCRIZIONE
BGS 189	SNODO A MACCHINA

CARATTERISTICHE
• finitura nera
• con sfera di tenuta
• peso 100 g



1/4" 3/8" 1/2" PRO+ CROMO

BGS articolo	DESCRIZIONE
BGS 9459	SET 3 PEZZI, SNODI

CARATTERISTICHE
• con scanalatura e foro per spina
• comprende:
- snodo 1/4" F - 1/4" M
- snodo 3/8" F - 3/8" M
- snodo 1/2" F - 1/2" M
• peso 420 g

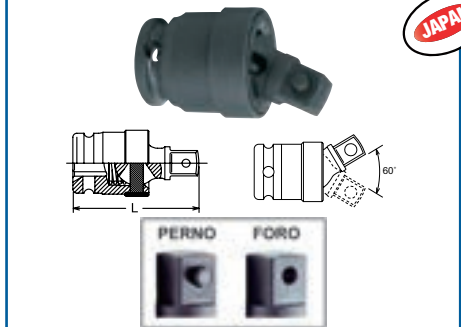

JAPAN

SNODO UNIVERSALE

Koken articolo		L mm	
13771-P	PERNO	48	1
13771	FORO	48	1

RIDUZIONI IMPACT