

TECHNICAL SPECIFICATIONS

Cod.	Campo mm	Risoluzione Resolución mm	A mm	B mm	E mm	F mm
CB0261	0 ÷ 1	0,001	42,8	60,7	19,8	18,5

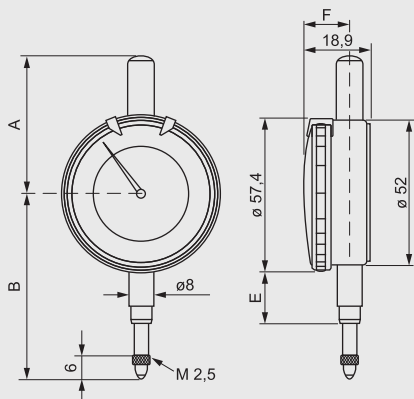

Comparatore millesimale Ø 58 mm.

Accuratezza secondo UNI 4180.

Comparatore analogico millesimale Ø 58 mm. Gambo in acciaio inossidabile e puntalino in metallo duro. Attacco cilindrico Ø 8 mm.

Comparador milesimal Ø 58 mm.

Precisión según UNI 4180.

Comparador analógico milesimal Ø 58 mm. Mango de acero inoxidable y punta de metal duro. Conexión cilíndrica Ø 8 mm.



TECHNICAL SPECIFICATIONS

Cod.	Campo mm	Risoluzione Resolución mm	A mm	B mm	E mm	F mm
CB0560	0 ÷ 5	0,001	40	60	23	16

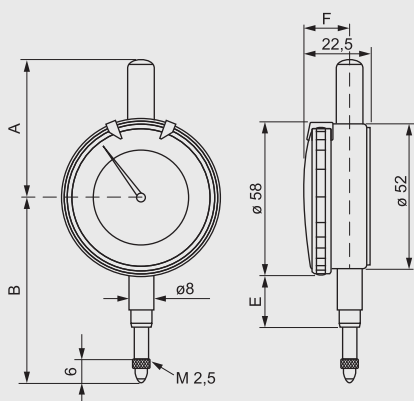

Comparatore analogico millesimale Ø 58 mm.

Corsa 5 mm. Gambo in acciaio inossidabile e puntalino in metallo duro. Preciso secondo UNI4180. Attacco cilindrico Ø 8 mm.

Comparador analógico milesimal Ø 58 mm.

Carrera 5 mm. Mango de acero inoxidable y punta de metal duro. Preciso según UNI4180. Conexión cilíndrica Ø 8 mm.

